

Absolute encoder GEL 15xF

Serial (SSI) or parallel interface,
PC-programmable

SENSORLINE

LENORD+BAUER

Technical information

version 01.06

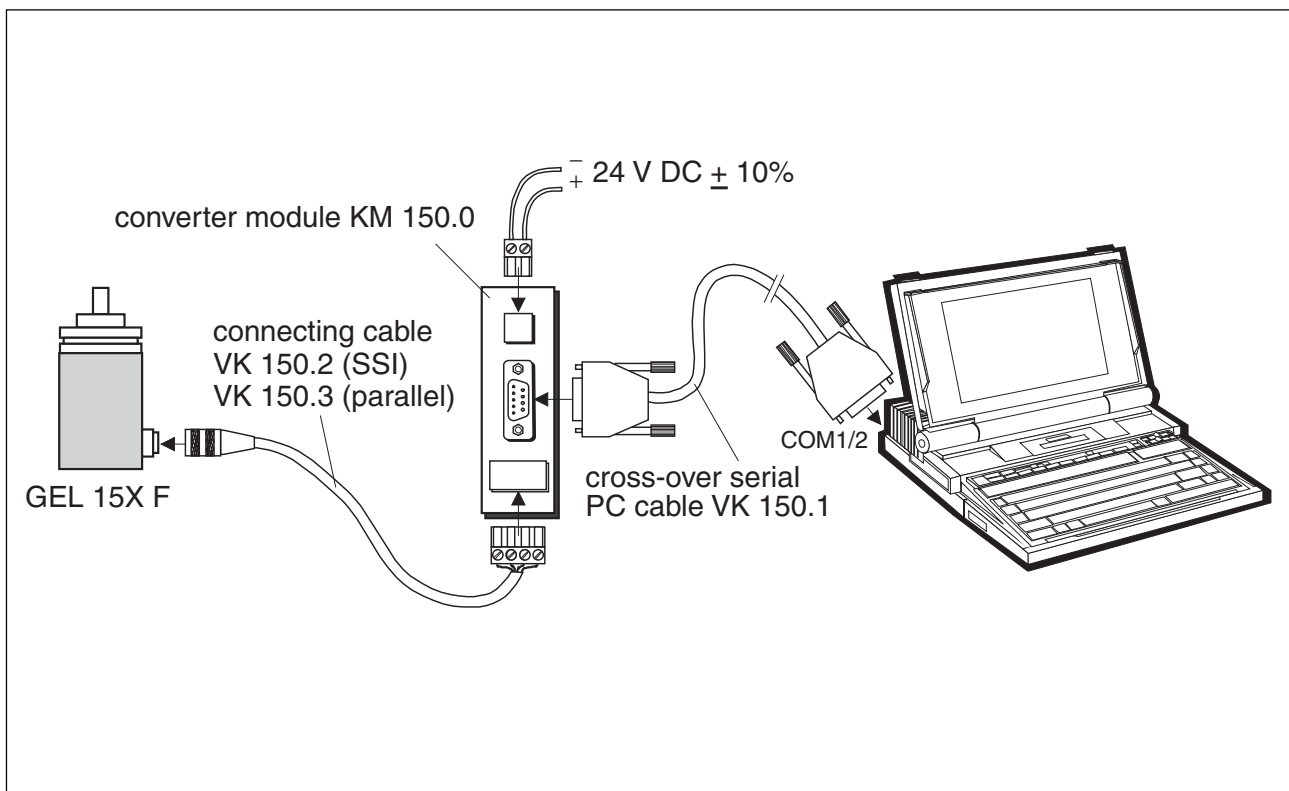

General information

Function

The GEL 15XF series has been developed with the intention of enabling the user to change plant-specific parameters. The encoder can be programmed by means of a PC via the encoder programming line.

The selected parameters stored in an E²PROM in the absolute encoder are protected against power failures.

The programming software BB 150 (3 1/2" diskette, 1.4 MB) for menu-guided programming runs on any IBM-compatible PC-AT with a main memory of 512 KB and DOS 3.1 or higher. The RS 485 interface signals are converted to the PC-compatible RS 232 interface in the converter cable.

Programmable parameters

- Resolution: 0.0002 to 4096.0000 steps/360°
- Measuring range: 1,2,4 ... 4,096 revolutions
- Output code: Gray, Gray-Tanne, BCD, Binary or Binary-Tanne
- Code direction: CW or CCW
- Logic polarity: positive or negative (only with parallel interface)
- Parity bit: ODD or EVEN
- Setmodes: Set Reference or Up-Down mode
- Reference value 1: 0 to total number of steps
- Reference value 2: 0 to total number of steps
- Offset value: - 32,768 ... + 32,768
- Length of register: 13, 16, 25 or 32 Bit (only with SSI interface)
- Monostable time: 1 ... 682 μs (only with SSI interface)
- Identification number: 0 ... 65,535 (ID number)

Setmodes

The functions **Set Reference** or **Up-Down Mode** can be programmed via inputs FE1 and FE2.

FE1	FE0	Setmode: Set Reference
0	0	normal coding mode
0	1	set reference point 1
1	0	set reference point 2
1	1	output value stored (latch)

FE1	FE0	Setmode: Up-Down mode
0	0	normal coding mode
0	1	reduce output value and set (down)
1	0	increase output value and set (up)
1	1	output value stored (latch)

The **Set Reference** mode permits setting of reference points 1 or 2. The reference values can be programmed by the user within the total number of steps.

In the **Up-Down Mode**, the output value of the absolute encoder can be increased or reduced by the user via the function inputs. The output change speed increases with the duration of signal application. Applying a logic 0 for a short time reset the output change speed. The set value is stored after about 6 seconds before the absolute encoder switches over to the normal coding mode. These functions can be used for electronic setting such as for changing the zero setpoint.

Timing diagrams

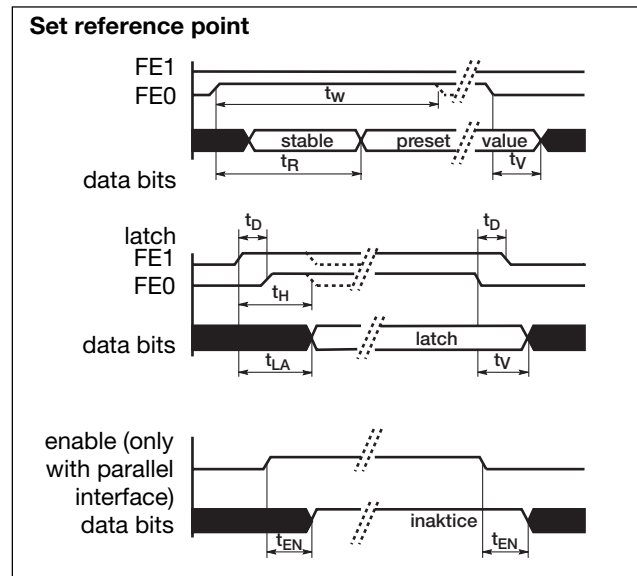

- t_V : delay = 1.1 ms max.
- t_H : hold = 750 μs min.
- t_w : wait = 70 ms min.
- t_R : response = 60 ms
- t_{LA} : latch response = 750 μs max.
- t_D : time difference of monostable circuits = 100 μs max.
- t_{EN} : response = 100 μs max.

Electrical data	
Sensor system	GaAlAs-diode-photo-array, photo-transistors
Measuring step deviation	$\leq \pm 2' 38''$
Parallel outputs	open collector, open emitter
Serial outputs (SSI)	RS 422 / 485
Parallel output frequency	max. 30 kHz at 10 bits/360°
Output code	Gray, Gray-Tanne, Binary, Binary-Tanne, BCD
Signal input E6 (code direction)	CW or CCW
Signal input E6 (latch)	via function inputs (FE)
Signal input E6 (enable)	circuit active or inactive
Operating voltage range	+ 11 V ... + 30 V DC
Operating current	80 mA typical, 120 mA max.
Electromagnetic compatibility (EMC)	electromagnetic emissions according to EN 61000-6-4 electromagnetic immunity according to EN 61000-6-2
Mechanical characteristics	
Operating speed	3,000 min ⁻¹ max. (permanent) 4,000 min ⁻¹ max. (short-time) Values for maximum shaft load and operating temperatures -20°C ... +60°C. Higher values possible under less stringent conditions.
Angular acceleration	10 ⁵ rad/s ² max.
Moment of inertia (rotor)	50 gcm ²
Operating torque	≤ 5 Ncm at a speed of 1,000 min ⁻¹
Starting torque	≤ 1 Ncm
Admissible load on shaft	250 N axial and radial
Bearing life	10 ⁹ revolutions
Weight	approx. 0.7 kg
Ambient conditions	
Operating temperature range	-20°C ... +60°C (optional -40°C ... +85°C)
Storage temperature range	-25°C ... +70°C
Admissible relative humidity	85 % without condensation
Schock resistance	200 m/s ² ; 11 ms (DIN IEC 68)
Vibration resistance	5 Hz ... 1,000 Hz; 100 m/s ² (DIN IEC 68)
Protection class (DIN 40050)	GEL 152/158 IP 65 (Nilos ring) GEL 154 IP 66 (radial packing ring)

Input/Output circuits

Synchronous Serial Interface (SSI)

Input E6

Function input active high

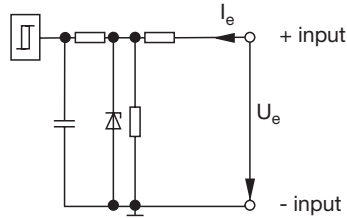

log 0 0 ... + 3.5 V
 log 1 + 11 V ... + 30 V

valid for signal: latch
 set
 enable
 code direction (counting direction)

D2651A

Output circuit for G, B, R

Output circuit 0
 open collector
 darlington
 (pull-down)

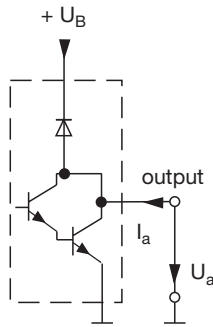

$I_A \leq 50 \text{ mA}$

Output circuit 2
 open emitter
 darlington
 (pull-up)

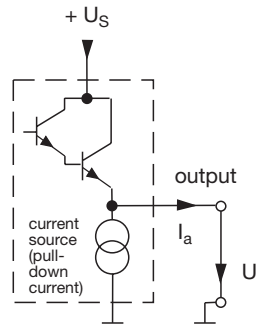

$I_A \leq 20 \text{ mA}$

Output circuit 3
 SSI (to RS 422/RS 485)

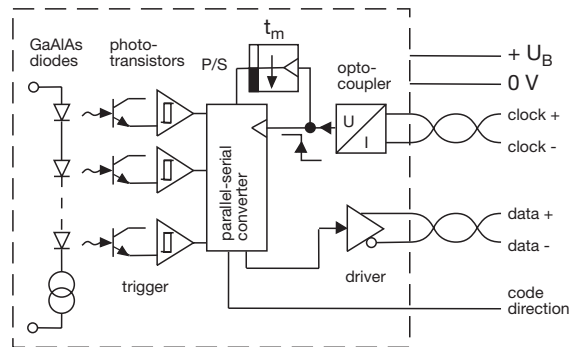

D6251A

Synchronous Serial Interface (SSI)

Advantages:

- lower costs and reduced work due to minimized wiring
- increased data safety due to repeat transmissions

- maximum noise immunity due to symmetrical and synchronous data signals

The parallel data word generated by the encoder is converted into a serial data word and transmitted synchronously with the clock signal to the receiver electronics.

Example

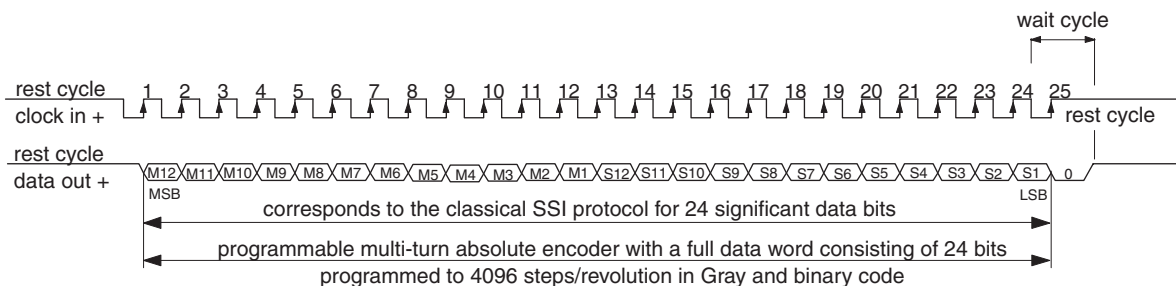

Proto2

Parallel interface

Pin layout for 37-pole sub-miniature connector (IP 30)

DB 37S

depth of connector approx. 15

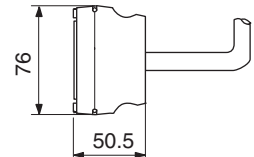

Solder side

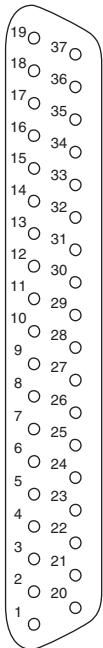

1 through 24	<i>Bit 1</i>	LSB depending on programming
	<i>Bit 24</i>	MSB depending on programming; bits not used are logic 0
25	<i>PR-</i>	interface for PC programming via
26	<i>PR+</i>	
27	<i>Error-Bit</i>	on error set to "0"
28	<i>Parity-Bit</i>	programmable
29	<i>not connected</i>	
30	<i>Function input 1</i>	input circuit E6
31	<i>Function input 0</i>	input circuit E6
32	<i>Enable</i>	input circuit E6
33	<i>Code direction</i>	input circuit E6, also programmable
34	<i>0 V</i>	reference potential
35	<i>Signal voltage</i>	5 ... 30 V DC (+U _S) only for 15xG4096A25
36	<i>Supply voltage</i>	11 ... 30 V DC (+U _B)
37	<i>Supply voltage</i>	0 V DC (-U _B) jumpered to pole 34

Serial interface (SSI)

Pin layout for 12-pole round connector (IP 65)

GG 723.12

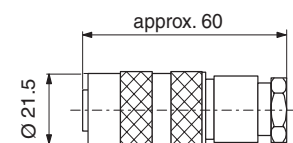

Solder side

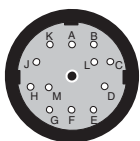

A	<i>Clock in -</i>	differential clock input (optocoupler)
B	<i>Clock in +</i>	for driver as per RS 422/485 standard
C	<i>Data out+</i>	differential data output with specification as per RS 422/485 standard
D	<i>Data out -</i>	
E	<i>PR-</i>	interface for PC programming via converter cable KV 150; differential transceiver as per RS 485 standard
F	<i>PR+</i>	
G	<i>not connected</i>	
H	<i>Code direction</i>	input circuit E6, also programmable
J	<i>Function input 1</i>	input circuit E6
K	<i>Function input 0</i>	input circuit E6
L	<i>Supply voltage</i>	U _B = +11 ... 30 V DC
M	<i>Supply voltage</i>	- U _B = 0 V DC

GW 723.12

(Please order separately)

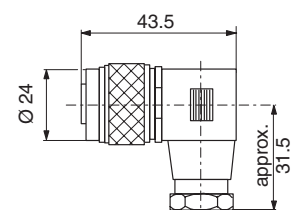

Dimensioned drawings

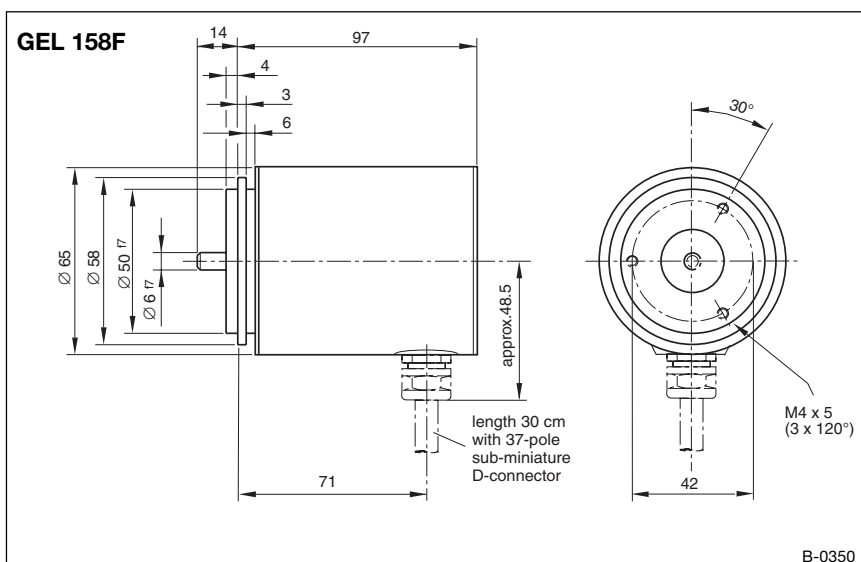
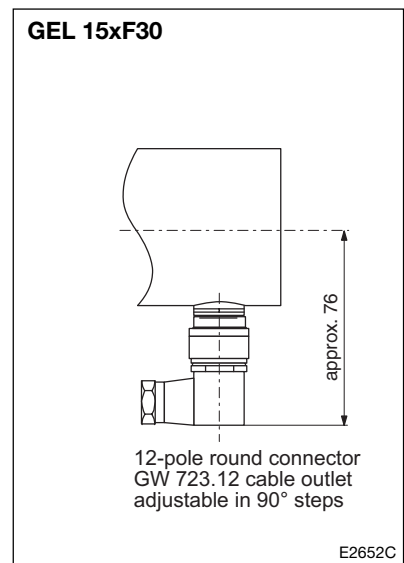
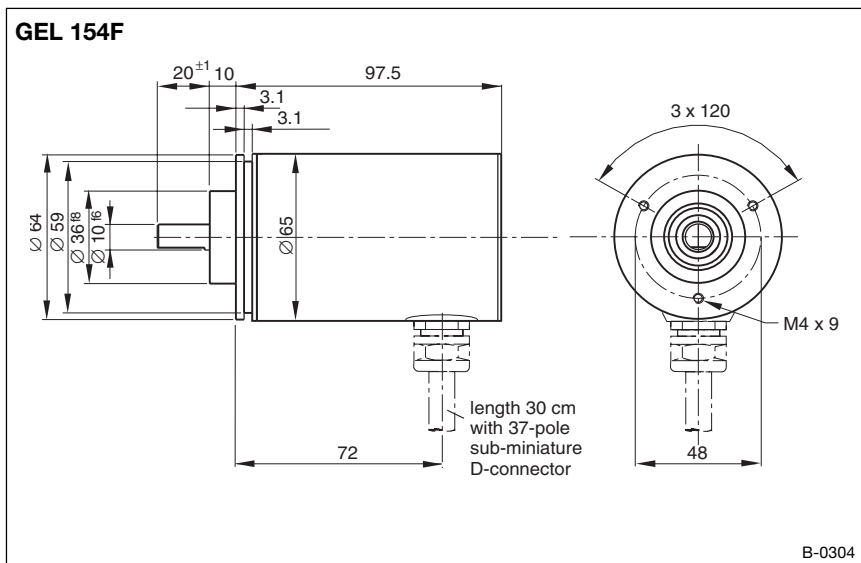
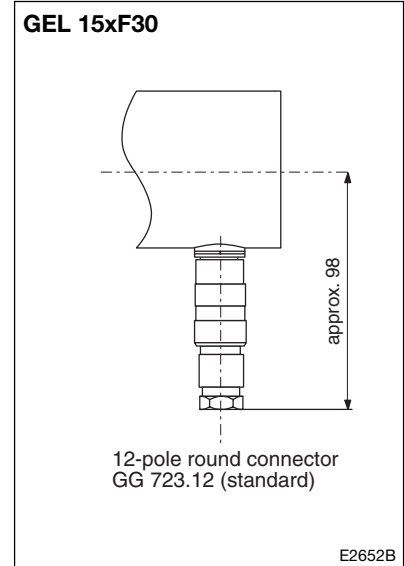
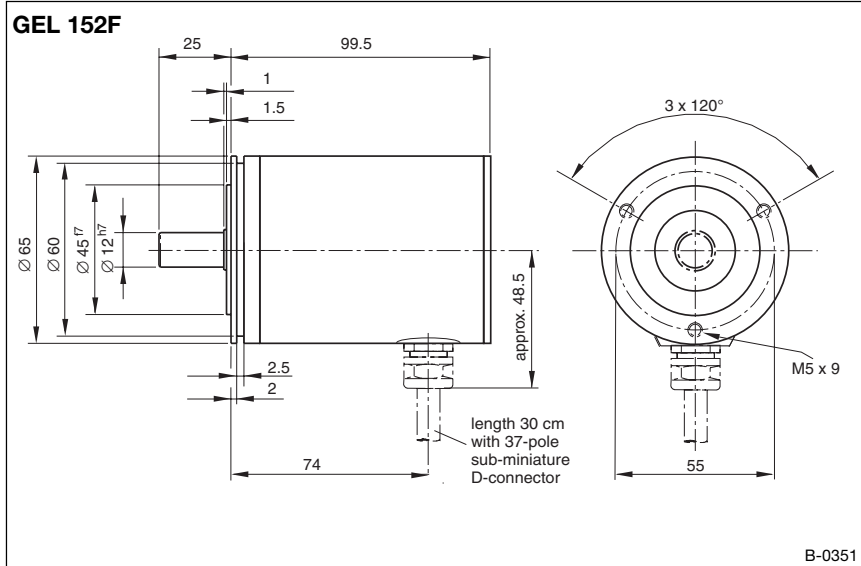

Available types, Accessories

Available types

Type	Output circuit	Included in scope of supply
GEL 152 F00	0 (pull-down)	37-pole sub-miniature D-mating connector
GEL 154 F00		
GEL 158 F00		
GEL 152 F20	2 (pull-up)	
GEL 154 F20		
GEL 158 F20		
GEL 152 F30	3 (SSI)	12-pole round connector, straight type GG 723.12 alternatively round connector, right-angle GW 723.12 (optional)
GEL 154 F30		
GEL 158 F30		

Accessories

- VK 150.1** cross-over serial connecting cable (2 m)
VK 150.2 connecting cable (SSI) 0.5 m
VK 150.3 connecting cable (parallel) 0.5 m
- KM 150.0** converter module incl. cross-over serial cable VK 150.1 (2 m)
- KM 150.1** converter module (SSI) with connecting cable VK 150.2 (0.5 m) incl. cross-over serial cable VK 150.1 (2 m)
- KM 150.2** converter module (parallel) with connecting cable VK 150.3 (0.5 m) incl. cross-over serial cable VK 150.1 (2 m)
- BB 150** software for programming of absolute encoder parameters

Spare parts

- GG 723.12** 12-pole round connector, straight (SSI)
GW 723.12 12-pole round connector, right-angle (SSI)
DB 37S 37-pole sub miniature D-connector, female

Reply-Fax

Customer-specific programming

Fax: +49 (0)2 08 / 67 62 92

Sender:

Name: Contact/person in charge:
 Street:
 Postal code/City:
 Phone: Phone:
 Fax: Fax:

Parameter	Range of values	Parallel interface		SSI interface	
		Basic programming	Pre-programming	Basic programming	Pre-programming
Resolution	0.0002 ... 4,096.000 steps /360° ¹⁾	4,096		4,096	
Measuring range	1, 2, 4 ... 4096 revolutions	4,096		4,096	
Output code	Gray-, Binary or BCD Gray-Tanne, Binary-Tanne	Gray		Gray	
Code direction	CW / CCW	CW		CW	
Logic polarity	positive or negative	positive			
Parity bit	ODD or EVEN	EVEN		EVEN	
Set modes	preset or Up-Down mode	preset		preset	
Reference value 1	0 ... total no. of steps	0		0	
Reference value 2	0 ... total no. of steps	0		0	
Offset value	-32,768 ... + 32,768	0		0	
Length of register	13, 16, 25 or 32 bits			32	
Monostable time	1 ... 682 µs			20	
Identification no.	0 ... 65,535	0		0	

¹⁾ with Gray-Tanne or Binary-Tanne only

Unless otherwise specified in the **Pre-Programming** column, the absolute encoders are supplied with the indicated **Basic Programming**.